

PEINER

Schnellmontagekran SMK 205/1

Fast self erecting tower crane

Grue à montage rapide

Max. Tragfähigkeit Lifting capacity Force de levage	4,0 t
Max. Ausladung Radius Portée	33 m
Max. Nutzlastmoment Load moment Couple de charge utile	473 kNm

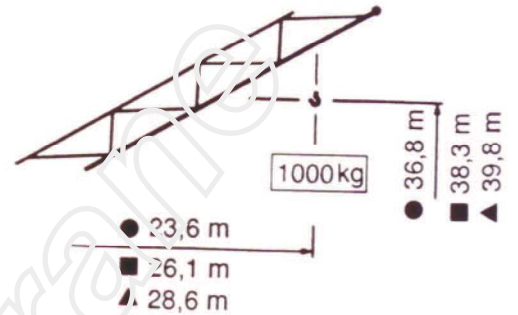







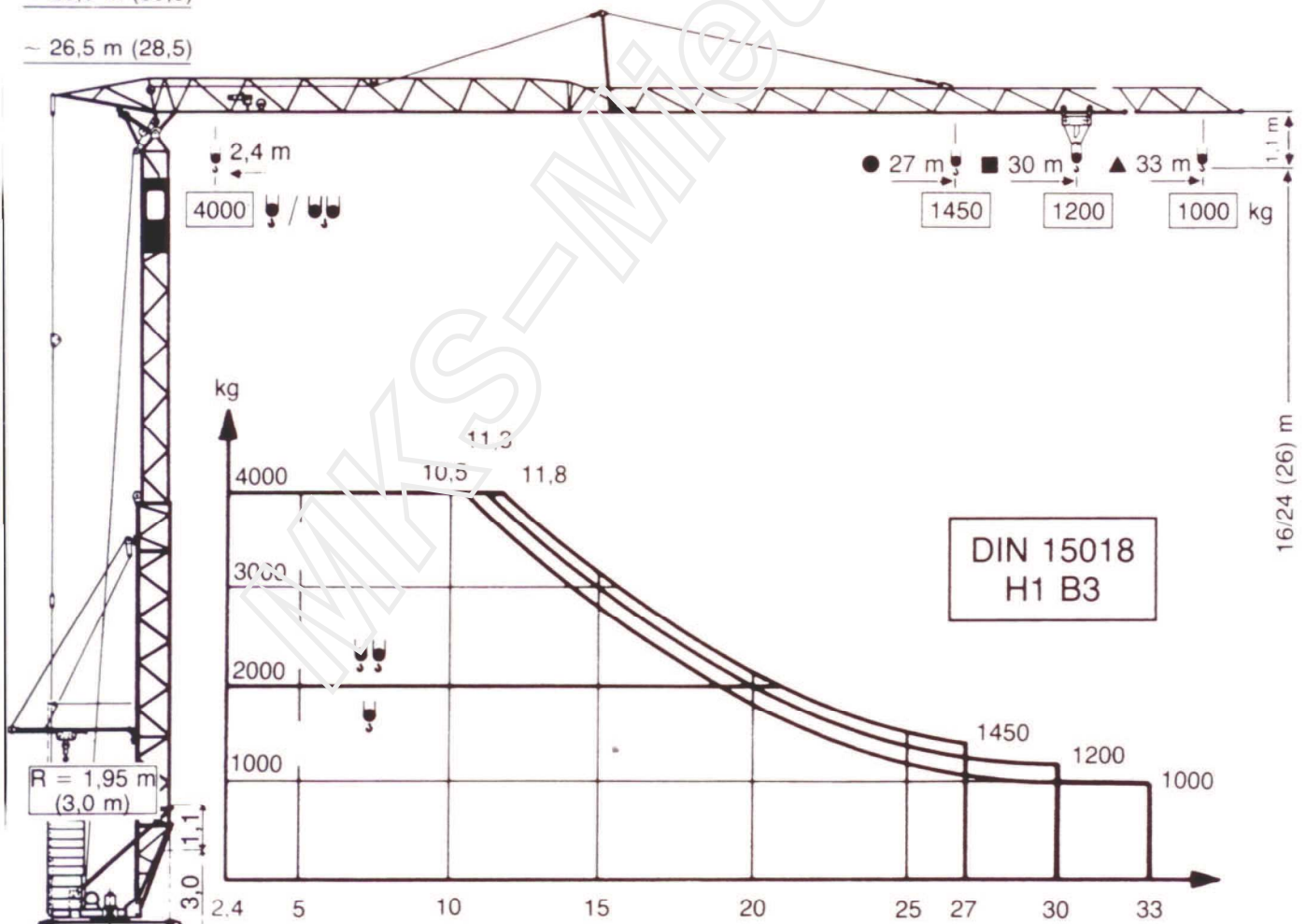







“City-Kran”

~ 28,5 m (30,5)

~ 26,5 m (28,5)



Geschwindigkeiten / speeds / Vitesses

Type		3 + 3				3 + 3				Motor-Leistung Power Puissance KW
				m/min. 45	kg 1000			m/min. 22	kg 2000	
PU11 / 4				22	2000			11	4000	11
				5,0 m/min.		2,5 m/min.				
KS 2 / 4		v = 20/40 m/min. (Steilstellung v = 20/40 m/min x 1000kg)								3,0
FT1 / 40		v = 25 m/min.								3,0
DIEO / 55		n = 0 → 0,9 min ⁻¹								3,0
380 V/50 Hz / 3 Ph		Anschlußwert / connection power / Puissance installée								~ 22 KW

Gewichte + Maße / weights and sizes / Poids et mesures

Konstruktionsgewicht Construction weight Poids de construction	kg	Standard-	City-Ausf.	Führerstand Sichthöhe Height of sight from drivers cabin Hauteur de vue de la cabine	m	22
		13 100				24
Gegengewicht Counterweight Contre-poids	D + CH kg	18 800	25 800	Kabeltrommel (Fahrweg) Cable winder (length of track) Enrouleur (longueur de voie)	m	60
max. Eckdruck max. wheel load Pression max. par galot	KN	175	210	Kabelquerschnitt Cable cross section Section du câble	mm ²	4 x 10
Spurweite / Radstand track gauge / wheel gauge Ecartement de voie / Empâtement	m	3,8		Schienenprofil Rail profile Profil de rail		S 33/S 49
Drehradius Radius of rotation Rayon de rotation	m	3,0	1,95			

Straßentransport

Road transport

Transport en route

